

DC/DC Converter

10 Watt

10 GRB 110 M24 □ □ □

$V_{I\text{ nom}} = 72\text{ V}, 110\text{ V}$

$V_{O\text{ nom}} = 24\text{ V}$ $I_{O\text{ nom}} = 0.425\text{ A}$

SYMBOL	PARAMETER	TEST CONDITIONS	MIN	TYP	MAX	UNIT
INPUT						
V_{IN}	Input voltage range	Continuously	50.4		137.5	V
$V_{IN\text{ Dyn}}$	Input voltage range dynamic	$V_{IN} = 43.2\text{ V} \dots 50.4\text{ V}$ for $t \leq 0.1\text{ s}$ $V_{IN} = 137.5\text{ V} \dots 154.0\text{ V}$ for $t \leq 1\text{ s}$	43.2		154.0	V
$V_{IN\text{ min}}$	Converter shutdown				43.0	V
$V_{IN\text{ max}}$	Converter shutdown		155		158	V
I_E	Input current	no load			15	mA
		Nominal load	$V_{IN} = 154.0\text{ V}, I_{OUT} = 0\text{ A}$	0.1		A
		Nominal load	$V_{IN} = 110.0\text{ V}, I_{OUT} = 0.425\text{ A}$	0.13		A
		Nominal load	$V_{IN} = 72.0\text{ V}, I_{OUT} = 0.425\text{ A}$ $V_{IN} = 43.2\text{ V}, I_{OUT} = 0.425\text{ A}$			0.4
	Input current integral	$V_{IN} = 154.0\text{ V}$			10	A ² s
$I_{IN\text{ max}}$	Switch on current at $V_{in} \geq V_{in\text{ min}}$	$I_{OUT} = 0.425\text{ A}$ $\Delta t \leq 100\text{ ms}$			4	A
	Input Fuse	External fuse recommended e.g. 2A				
C_{IN}	Converter input capacitance				1.0	μF
	External Line Inductance				25	μH
	Reverse input protection	parallel diode + external fuse			1.5KE160A	

OUTPUT: Power Unit

$P_{OUT\text{ Nom}}$	Output power	$50.4\text{ V} \leq V_{IN} \leq 154.0\text{ V}$		10		W
$V_{OUT\text{ Nom}}$	Output voltage adjustment, factory set	$50.4\text{ V} \leq V_{IN} \leq 137.5\text{ V}$	23.9	24.0	24.1	V
ΔV_{OUT}	Load regulation static	$43.2\text{ V} \leq V_{IN} \leq 154.0\text{ V}$ $0\text{ A} \leq I_{OUT} \leq 0.425\text{ A}$ $T_A = -40^\circ\text{C} \dots +70^\circ\text{C}$	$\leq 3.0\% V_{out\text{ nom}}$			V
$\Delta V_{O\text{ dyn.}}$	Load regulation dynamic	$43.2\text{ V} \leq V_{IN} \leq 154.0\text{ V}$ Pulse load: 20 - 80 - 20 % x I_{OUT}			200	mV
t_{dyn}	Response time	$43.2\text{ V} \leq V_{IN} \leq 154.0\text{ V}$ Pulse load: 20 - 80 - 20 % x I_{OUT}		1	2	ms
$V_{O\text{ rms}}$	Ripple	$43.2\text{ V} \leq V_{IN} \leq 154.0\text{ V}$ Nominal load BW 300 kHz		100	150	mV
$V_{O\text{ pp}}$	Noise	$43.2\text{ V} \leq V_{IN} \leq 154.0\text{ V}$ Nominal load BW 20 MHz			200	mV
t_{on}	Turn on time V_o	$50.4\text{ V} \leq V_{IN} \leq 137.5\text{ V}, 0\text{ A} \leq I_{OUT} \leq 0.425\text{ A}$ resistive load			100	ms
t_h	Hold Up Time	$50.4\text{ V} \leq V_{IN} \leq 137.5\text{ V}$ $0\text{ A} \leq I_{OUT} \leq 0.425\text{ A}$	-	-	-	ms
	Overvoltage Protection	$43.2\text{ V} \leq V_{IN} \leq 154.0\text{ V}$ $0\text{ A} \leq I_{OUT} \leq 0.425\text{ A}$	Transil diode 1.5KE27A			V
I_{OUT}	Output current	$43.2\text{ V} \leq V_{IN} \leq 154.0\text{ V}$		0.425		A
	Output current limitation	$43.2\text{ V} \leq V_{IN} \leq 154.0\text{ V}$	0.5			A
I_{AK}	Output short circuit current	short circuit between + V_o and - V_o $43.2\text{ V} \leq V_{IN} \leq 154.0\text{ V}$			1.5	A
C_o	Converter Capacitance			0.5		mF

OUTPUT: Signals

Signal		LED yellow	
--------	--	------------	--

GENERAL SPECIFICATIONS

f	Switching frequency	$V_{IN} = 110\text{ V}, I_{OUT} = 0.425\text{ A}$		125		kHz
η	Efficiency	$P_{OUT} \geq 0.7 \times P_{OUT\text{ Nom}}$	77	83		%
	MTBF (SN 29500)	$V_{IN} = 110\text{ V}, I_{OUT} = 0.425\text{ A}, T_A = +40^\circ\text{C}$		500 000		h
	No load, short circuit proof		Continuously			

DC/DC Converter

10 Watt

10 GRB 110 M24 □ □ □

LED

SYMBOL PARAMETER TEST CONDITIONS MIN TYP MAX UNIT

SAFETY / DIMENSIONS

	Creepage, Clearance PCB, FR4, V0	Input – Output Input – Case Output – Case	2.0 1.0 1.0			mm mm mm
	Converter Dielectric Strength Test each unit ramp function 2 s – 3 s – 2 s	Input – Output Input – Case Output – Case			2100 1500 500	V V V
	Connector	Input: + V _{IN} und – V _{IN} Output: + V _{OUT} und – V _{OUT} PE	terminal 6 pol. 1 mm ² 1,5 mm ²			
	Protection Class, Protection degree		I, IP 40			
	Dimensions <i>see drawing</i>	w x h x d Wall mounting w x h x d Din rail mounting TS35	98 x 104.6 x 38 70 x 98 x 39			mm mm
	Assembling	Wall mounting Din rail mounting	4 x M4 with Clip for TS 35			
	Weight		210			g

ENVIRONMENTAL CONDITIONS

T _A	Operating Range	Continuously EN 50155 class T3	- 40		+ 70	°C
T _{Sto}	Storage Range		- 40		+ 70	°C
	Cooling		convection			
	Humidity	EN 50155, IEC 60571	75% averaged year, 95% 30 days			
	Vibration / Shock Valid only for wall mounting	IEC 61373, IEC 68-2-27, BN 411002 Cat. I 3 shocks each Axis	50 m / s ² , 30 ms			

EMC

	Emission	Line conducted and radiated	EN 50121 - 3 - 2: 2001
	Immunity	ESD EN 61000 - 4 - 2	6 kV / 8 kV performance criteria - B -
		High Frequency Field EN 61000 - 4 - 3	10 V / m 80 MHz ... 1 GHz performance criteria - A -
		Burst EN 61000 - 4 - 4	Level 3 asym., sym. performance criteria - A -
		Surge EN 61000 - 4 - 5	2 kV asym. / 1 kV sym. R _i = 42 Ω, perf. criteria - A -
		HF – Current Injection EN 61000 - 4 - 6	10 V _{eff} , R _i = 150 Ω performance criteria - A -

STANDARDS

Applied Standards:	EN 50155: 2004	BN 411 002	EN 50124 - 1: 2004	EN 50121 - 3 - 2: 2006	IEC 60571
	SN 29500	prEN 50121 - 1	prEN 50125 - 1	EN 60068 - 2 - 6, 2...27	EN 61000 - 4 - 2...6
	IEC 571	IEC 61373: 1999	EN 60721 - 3 - 5	EN 61373 : 1999	EN 60529

Technical specifications valid for: - 40° C ≤ T_A ≤ + 70° C, 50.4 V ≤ V_{IN} ≤ 137.5 V, unless otherwise noted.

Dimensions (in mm) and pin assignment:

Din rail mounting: 10 GRB 110 M24 H00

Wall mounting: 10 GRB 110 M24 W00

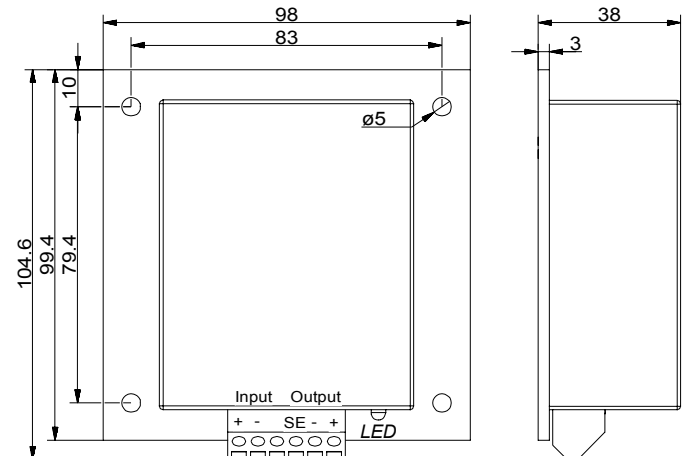
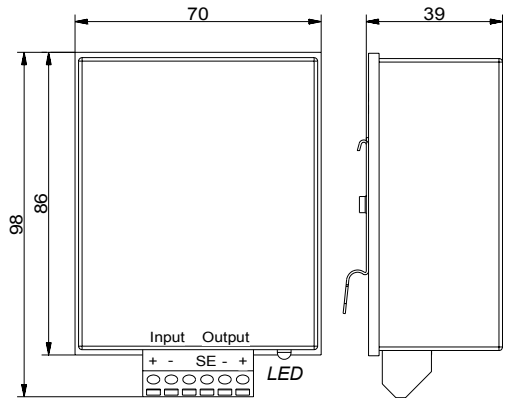

Order code:

10 GRB 110 M24 □ □ □ please select

H 0 0 = Din rail mounting TS35
W 0 0 = Wall mounting